

# Installation Manual for TSL/MD3/100FS

**TSL/MD3/100FS**

Tesla Model 3 Full-Set Package

Part Nr. 280078

---

**Please read installation manual carefully before beginning  
installation!**



**rainbow**

Rainbow Audio GmbH - Bernbrunnerstr. 54 - 74831 Gundelsheim

[www.rainbow-audio.de](http://www.rainbow-audio.de)

[info@rainbow-audio.de](mailto:info@rainbow-audio.de)



Dear Music Lover,

We congratulate you on your purchase of our superior product and thank you for placing your trust in rainbow. With over 30 years of engineering expertise in car audio speakers and belief in Golden Spiral for product design, rainbow has created a wide range of products that reproduce life-like sound with all the details and emotions you can hope for. Rainbow guarantees outstanding quality and we wish you many pleasant hours enjoying your favorite music with our high-performance products. We have put together this installation manual with great consideration of different mechanical and acoustical features to help you better understand and operate rainbow products. And we'd love to hear your questions, feedback and improvement suggestions via email [info@rainbow-audio.de](mailto:info@rainbow-audio.de).

Best wishes,  
Your Rainbow Team

## **Safety Instruction**

### **Attention**

Please read all warnings found in this manual. This information is included and highlighted to inform you of the potential risks of personal injury or damage to property.

**Our products are intended for those who want to upgrade their car audio systems and enjoy unbeatable sound performance in cars. The relevant safety regulations regarding related auto parts, the regulations of internal vehicle safety, as well as the regulations of the authorized vehicle manufacturers should be followed diligently.**

### **Hearing Damage**

**Continuous exposure to sound pressure levels over 85 dB may cause permanent hearing loss. High-powered auto sound system could produce sound pressure levels over 130 dB, which may cause damage to hearing. Use common sense and avoid such risks.**

### **Volume and Driver Awareness**

Use of audio components can impair your ability to hear necessary traffic sounds and may constitute a safety hazard while driving your automobile.

Rainbow accepts no liability for hearing loss, bodily injury or property damage as a result of use or misuse of this product.

**Installation Notice**

Do not use your automobile until all components of the loudspeaker system have been secured to the interior framework. Failure to do so may turn a component into a dangerous, flying projectile during a sudden stop or accident.

We recommend disconnecting the battery before beginning installation of the loudspeaker system. Please ask your car dealer if disconnecting the battery is feasible without any problems.

Always be meticulous when removing interior trim panels. Car manufacturers use a variety of fastening devices that can be damaged in the disassembly process.

If sheet metal must be cut or removed, contact your authorized car dealer for professional advice. By damage to supporting body structures the safety certificate may be withdrawn.

**Shock Hazard!**

Do not touch the connectors while the system is running.

## **Mechanical Installation**

This Tesla full-set package offers plug and play solutions and can be easily mounted in the car. Remove necessary panels, and activate the factory speaker system with the plug and play cable. Next, install rainbow DSP amplifier and subwoofer and make sure to properly connect the DSP amplifier. Then reattach the panels removed.

### **Warranty**

All rainbow products come with a year's warranty on all parts, starting from the date of purchase from the authorized retailer. Only the first buyer is entitled to this warranty policy, which would be invalid in case of products being transferred.

The warranty covers all material and manufacturing defects, however it does not cover mechanical defects, defects caused by electrical overload and foreign interference by unauthorized people.

This document is protected by copyright. It can not be, in whole or in part, duplicated, printed, transmitted or otherwise exploited in any manner without written permission of Rainbow Audio GmbH, Germany. Rainbow reserves the right to modify or improve the desired products without prior notice. All rights reserved.

## TECHNICAL DATA

<b>Subwoofer</b>	
Size	10 inch
RMS power	80 + 80 W
Peak power	160 + 160 W
Impedance	2 + 2 Ohm
Frequency response	33Hz - 600Hz
Sensitivity	83 dB/W/m

<b>DSP amplifier L10.1</b>	
Input signal	8-channel high level
Output signal	8*50 W + 2*150 W + 1*300 W
Input sensitivity	28Vpp (high level)
High level input impedance	107 Ohm
Frequency response	20Hz - 20kHz
S/N	≥90dB
THD	≤0.01%
Dimensions (L*W*H)	294mm*128mm*52mm

## TECHNICAL DATA

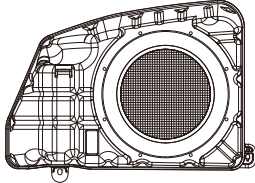
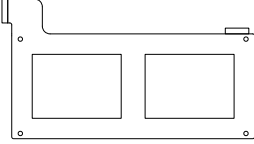
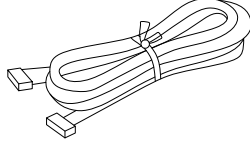
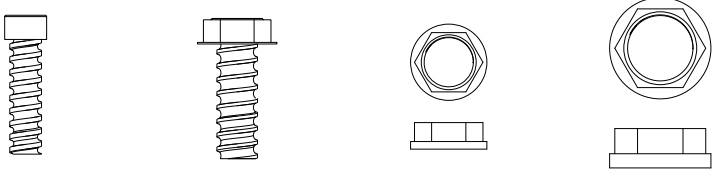
<p><b>DSP amplifier L10.1</b></p>	<p><b>10 inch non-pressed paper cone subwoofer with ABS+fiber enclosure</b></p>
 <p>x1</p>	 <p>x1</p>
<p><b>DSP amplifier rack</b></p>	<p><b>Plug and play cable kit</b></p>
	
<p><b>Screws kit</b></p>	
	

亲爱的音乐爱好者：

祝贺您购买了我们的优质产品，感谢您对彩虹的信任。彩虹拥有超过30年的汽车音响产品开发技术和生产经验，并遵循拥有两千多年历史的黄金分割率，制造出富有音乐感、声音自然动听的音响器材。彩虹汽车音响音质卓越，性能优良，让您尽情享受音乐之美。我们结合了不同的机械和汽车声学特点编写了这本安装手册，帮助您更好地了解和使用彩虹产品。如您有任何疑问、反馈和改善建议，请发邮件至info@rainbow-audio.de，我们将不胜感激。

最美好的祝愿

彩虹团队

## 安全指南

### 注意

请仔细阅读用户手册中的警示，我们在此注明并强调这些信息是为提醒您免受潜在的人身伤害或设备损坏。

如您想要升级汽车音响系统、乐享旅程，彩虹产品一定是您的不二之选。汽车零部件相关安全守则，车内安全守则和授权汽车生产商相关守则都须严格遵守。

### 听力损害

长时间聆听高于85分贝音量的声音可能会造成永久性听觉损失。而大功率音响系统产生的声音高于130分贝，可能会损伤听力。请合理调节系统音量及聆听时间，避免以上风险。

### 音量和安全驾驶

驾驶时，使用音响系统可能会让你听不清周围的交通声，进而引发交通事故。

彩虹对因产品使用不当引起的听力损伤、身体伤害或产品性能损坏概不负责。

### 安装须知

扬声器系统的全部元件未在车内固定好之前，不要驾驶汽车。否则，在急刹车或汽车事故时，扬声器元件可能成为危险的抛射物。

建议在开始安装扬声器系统之前取下汽车蓄电池。请咨询您的汽车经销商这样操作是否可行，不会引发任何问题。

拆卸内饰板时须格外小心。汽车生产商使用的多种紧固装置都可能在拆卸过程中被损坏。

如需切割或拆卸金属板，请联系授权汽车经销商，获取专业建议。支撑结构损坏，可能会导致安全证书被撤回。

触电危险！

音响系统运行时，不要触摸接线端口。

## 机械安装

彩虹特斯拉专用的套装产品，提供了简单的施工安装方案。拆下原车内饰，通过专用线束激活原车扬声器，并加装专用DSP功放和专用低音炮，确保DSP功放的专用线束对插正确，再还原内饰，无损安装既已完成。

质保

彩虹承诺为所有产品提供1年的法定质保期，确保所有部件在保修期内良好运行。保修期从授权经销商处购买产品之日开始计算。只有一手客户享受质保政策，保修权不可转让。

保修对象涵盖材料及生产缺陷。而机械损坏、电压过载引起的损坏、非授权人员对产品维修或拆卸造成的故障损坏皆不属于保修范围。

本文档受版权保护。未经彩虹公司事先书面许可，禁止以任何形式复制、打印、转发或利用部分或全部内容。彩虹公司保留修改或改进产品的权利，恕不另行通知。版权所有，翻版必究。

<b>低音炮</b>	
口径	10寸
额定功率	80 + 80 W
峰值功率	160 + 160 W
阻抗	2 + 2 Ohm
频率响应	33Hz - 600Hz
灵敏度	83 dB/W/m

<b>DSP 功放 L10.1</b>	
输入信号	8 路高电平
输出信号	8*50 W + 2*150 W + 1*300 W
输入灵敏度	28Vpp (高电平)
高电平输入阻抗	107 Ohm
频率响应	20Hz - 20kHz
信噪比	≥90dB
总谐波失真	≤0.01%
尺寸 (长*宽*高)	294mm*128mm*52mm

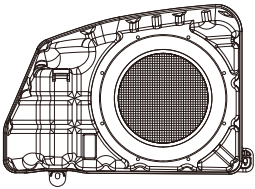
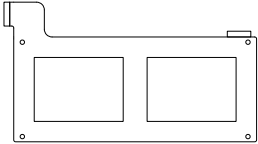
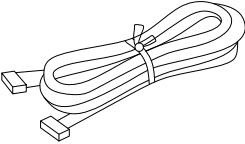
<p>DSP 功放 L10.1</p>	<p>10寸黑色松压纸盆白色玻纤防尘帽低音炮 带ABS+纤维低音炮箱体</p>
 <p style="text-align: right;">×1</p>	 <p style="text-align: right;">×1</p>
<p>DSP功放支架</p>	<p>DSP功放专用线束</p>
	
<p>螺丝包</p>	
